

Front board control panel  
Pick-Up/Full-Mag/Safe/De-Mag

2m cable,  
optional spiral cable 1-5m

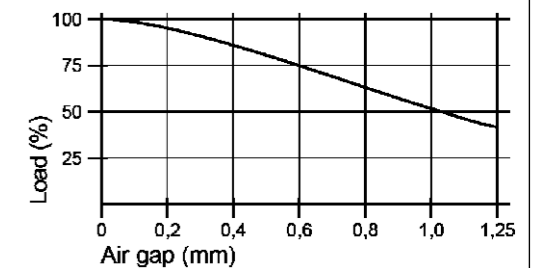
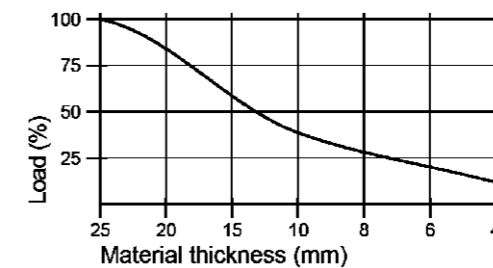
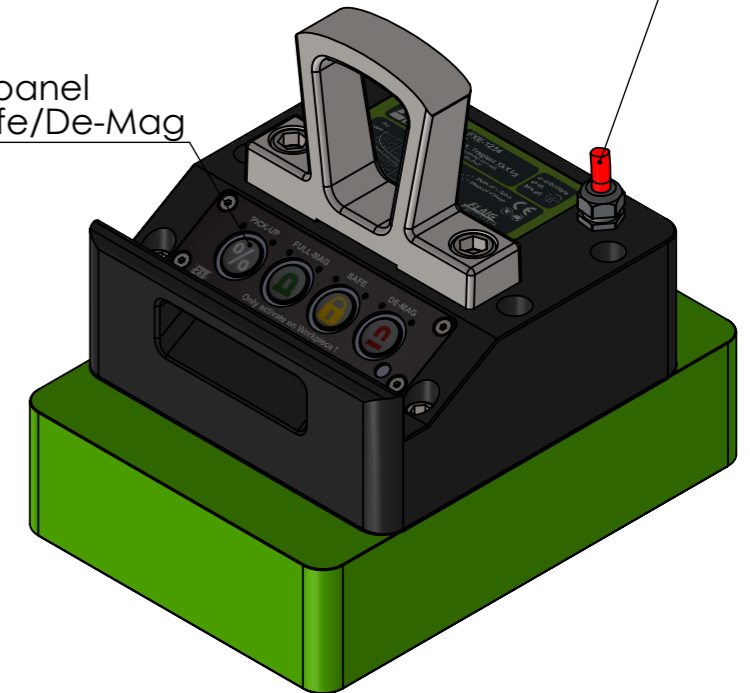

### Specification FXE 1500-80

Nominative Force: 54kN	lifting capacity EN 13155/WLL
Materialthickness >25mm (100%)	WLL= 1500kg
6,8kVA	
U: 380-480V Pulse	Protection type IP 65
R: 4Ω	Protection category SK I

Schutzvermerk nach DIN ISO 16016 beachten!  
Nachdruck nur mit unserer Genehmigung!  
All rights reserved according to DIN ISO 16016!  
Reprint with our permission only!

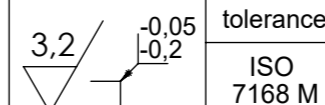

tolerance  
ISO  
7168 M

material: weight: 52kg

drawing no.: **0018536**

### Max. Load capacity at sheets and 4-edge pipes

T material thickness	Lmax (mm)	Wmax (mm)	Wll (kg)
>=8mm	2000	1500	300
>=10mm	2500	1500	450
>=15mm	2500	1500	900
>=25mm	2500	2000	1500

**FLAIG**  
Magnetsysteme  
www.flraig-te.de

description: **FXE 1500-80**

part no.: **10601502** sheet 1 / 1  
A3  
scale: 1:4 Status: Freigegeben